



# Option Modules

## Encoder Option

HA502217U001 Issue 2  
Technical Manual

aerospace  
climate control  
electromechanical  
filtration  
fluid & gas handling  
hydraulics  
pneumatics  
process control  
sealing & shielding



---

## AC30V Encoder Option

### Technical Manual HA502217U001 Issue 2

Compatible with Firmware version 1.5 or later

Copyright 2014 Parker Hannifin Manufacturing Limited

All rights strictly reserved. No part of this document may be stored in a retrieval system, or transmitted in any form or by any means to persons not employed by a Parker company without written permission from Parker Hannifin Ltd. Although every effort has been taken to ensure the accuracy of this document it may be necessary, without notice, to make amendments or correct omissions. Parker cannot accept responsibility for damage, injury, or expenses resulting therefrom.

Parker Hannifin Manufacturing Limited is referred to throughout this document as Parker.

#### **WARRANTY**

The general terms and conditions of sale of goods and/or services of Parker Hannifin Europe Sarl's, Luxembourg, Switzerland Branch, Etoy, apply to this product unless otherwise agreed. The terms and conditions are available on our website

[www.parker.com/termsandconditions/switzerland](http://www.parker.com/termsandconditions/switzerland).



**FAILURE OR IMPROPER SELECTION OR IMPROPER USE OF THE PRODUCTS DESCRIBED HEREIN OR RELATED ITEMS CAN CAUSE DEATH, PERSONAL INJURY AND PROPERTY DAMAGE.**

This document and other information from Parker-Hannifin Corporation, its subsidiaries and authorized distributors provide product or system options for further investigation by users having technical expertise.

The user, through its own analysis and testing, is solely responsible for making the final selection of the system and components and assuring that all performance, endurance, maintenance, safety and warning requirements of the application are met. The user must analyze all aspects of the application, follow applicable industry standards, and follow the information concerning the product in the current product catalog and in any other materials provided from Parker or its subsidiaries or authorized distributors.

To the extent that Parker or its subsidiaries or authorized distributors provide component or system options based upon data or specifications provided by the user, the user is responsible for determining that such data and specifications are suitable and sufficient for all applications and reasonably foreseeable uses of the components or systems.

# Safety Information



## Requirements

**IMPORTANT:** Please read this information *BEFORE* installing the equipment.

### Intended Users

This manual is to be made available to all persons who are required to install, configure or service equipment described herein, or any other associated operation.

The information given is intended to highlight safety issues, EMC considerations, and to enable the user to obtain maximum benefit from the equipment.

Complete the following table for future reference detailing how the unit is to be installed and used.

INSTALLATION DETAILS	
<b>Model Number</b> <i>(see product label)</i>	
<b>Where installed</b> <i>(for your own information)</i>	

### Application Area

The equipment described is intended for industrial motor speed control utilising AC induction or AC synchronous machines

### Personnel

Installation, operation and maintenance of the equipment should be carried out by competent personnel. A competent person is someone who is technically qualified and familiar with all safety information and established safety practices; with the installation process, operation and maintenance of this equipment; and with all the hazards involved.

### Product Warnings

 <b>DANGER</b> Risk of electric shock	 <b>WARNING</b> Hot surfaces	 <b>Caution</b> Refer to documentation	 <b>Earth/Ground</b> Protective Conductor Terminal
--	---	---	---

## CAUTION!

### APPLICATION RISK

- The specifications, processes and circuitry described herein are for guidance only and may need to be adapted to the user's specific application. We cannot guarantee the suitability of the equipment described in this Manual for individual applications.

### RISK ASSESSMENT

Under fault conditions, power loss or unintended operating conditions, the drive may not operate as intended. In particular:

- Stored energy might not discharge to safe levels as quickly as suggested, and can still be present even though the drive appears to be switched off
  - The motor's direction of rotation might not be controlled
  - The motor speed might not be controlled
  - The motor might be energised
  - Stored energy
  - Supply disconnects
  - Sequencing logic
  - Unintended operation
- A drive is a component within a drive system that may influence its operation or effects under a fault condition. Consideration must be given to:

## Safety Information



### **DANGER! - Ignoring the following may result in injury**

1. This equipment can endanger life by exposure to rotating machinery and high voltages.
2. The equipment must be permanently earthed due to the high earth leakage current, and the drive motor must be connected to an appropriate safety earth.
3. Ensure all incoming supplies are isolated before working on the equipment. Be aware that there may be more than one supply connection to the drive.
4. There may still be dangerous voltages present at power terminals (motor output, supply input phases, DC bus and the brake, where fitted) when the motor is at standstill or is stopped.
5. For measurements use only a meter to IEC 61010 (CAT III or higher). Always begin using the highest range. CAT I and CAT II meters must not be used on this product.
6. Allow at least 5 minutes for the drive's capacitors to discharge to safe voltage levels (<50V). Use the specified meter capable of measuring up to 1000V dc & ac rms to confirm that less than 50V is present between all power terminals and between power terminals and earth.
7. Unless otherwise stated, this product must NOT be dismantled. In the event of a fault the drive must be returned. Refer to "Routine Maintenance and Repair".

### **WARNING! - Ignoring the following may result in injury or damage to equipment**

#### **SAFETY**

**Where there is conflict between EMC and Safety requirements, personnel safety shall always take precedence.**

- Never perform high voltage resistance checks on the wiring without first disconnecting the drive from the circuit being tested.
- Whilst ensuring ventilation is sufficient, provide guarding and /or additional safety systems to prevent injury or damage to equipment.
- When replacing a drive in an application and before returning to use, it is essential that all user defined parameters for the product's operation are correctly installed.
- All control and signal terminals are SELV, i.e. protected by double insulation. Ensure all external wiring is rated for the highest system voltage.
- Thermal sensors contained within the motor must have at least basic insulation.
- All exposed metalwork in the Inverter is protected by basic insulation and bonded to a safety earth.
- RCDs are not recommended for use with this product but, where their use is mandatory, only Type B RCDs should be used.

#### **EMC**

- In a domestic environment this product may cause radio interference in which case supplementary mitigation measures may be required.
- This equipment contains electrostatic discharge (ESD) sensitive parts. Observe static control precautions when handling, installing and servicing this product.
- This is a product of the restricted sales distribution class according to IEC 61800-3. It is designated as "professional equipment" as defined in EN61000-3-2. Permission of the supply authority shall be obtained before connection to the low voltage supply.

**Contents..... Page No.**

<b>AC30V Encoder Option .....</b>	<b>1</b>
Introduction .....	1
Understanding the Product Code .....	1
Installation.....	2
User Terminals.....	4
User Wiring .....	5
Terminal Cable Specification .....	5
Motor Thermistor.....	6
Programming.....	7
Specification .....	8
Example Application .....	8
Incremental Pulse Encoder .....	9
Encoder Inputs .....	10
Programming.....	11
Power Supply .....	12
Programming.....	13
Specification.....	14
Differential or Single-Ended Signalling.....	16
Example Applications .....	17
Specification.....	21
Encoder Cable.....	22
Recommended Encoders.....	23
Setting up Closed Loop Operation.....	24
Environmental.....	25
Registration, Evaluation, Authorisation and Restriction of Chemicals (REACH) .....	25
Restriction of Hazardous Substances (RoHS).....	25
Waste Electrical and Electronic Equipment (WEEE) .....	26

# AC30V ENCODER OPTION

## Introduction

---

The Encoder Option Module is compatible with the AC30V range of drives, with firmware version 1.5 or later. It offers compatibility with a wide range of encoders from many manufacturers.

Using this module enables the AC30V to operate in closed-loop speed control. Alternatively the encoder input may be used as a speed setpoint, with the drive operating in open-loop (volts / Hz) mode.

## Understanding the Product Code

---

The Encoder Option Module product code is 7004-XX-YY.

Product Code	Features available
7004-04-00	1 x Incremental Pulse Encoder 1 x Motor Thermistor Input
7004-04-00	Standard optimized minimal conformal coating



## Installation

1. This equipment contains electrostatic discharged (ESD) sensitive parts. Observe static control precautions when handling, installing and servicing this product.
2. Refer to the AC30V product manual Chapter 1: Safety before installing or removing an encoder option.
3. Ensure all power is removed from the drive.
4. Remove the GKP by pulling from the top down, and remove.

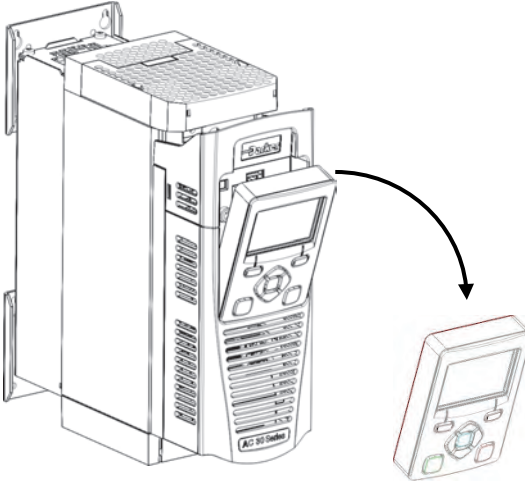

5. After removing the screw, slide the VCM lower cover down slightly and then remove.

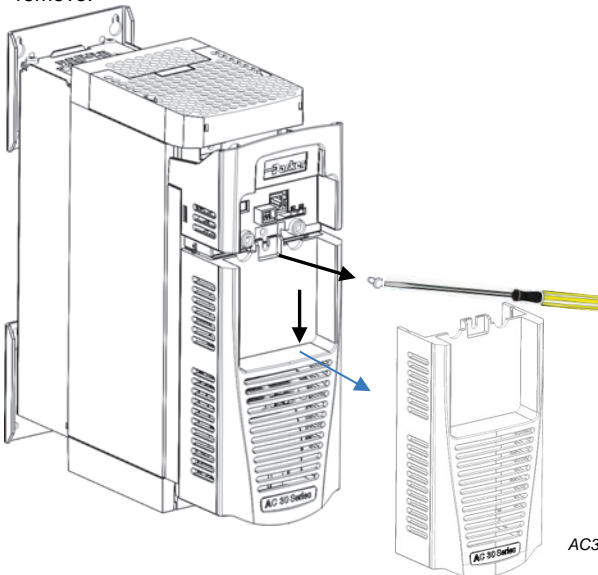



6. Click the Option into place and tighten the retaining screw, as shown.

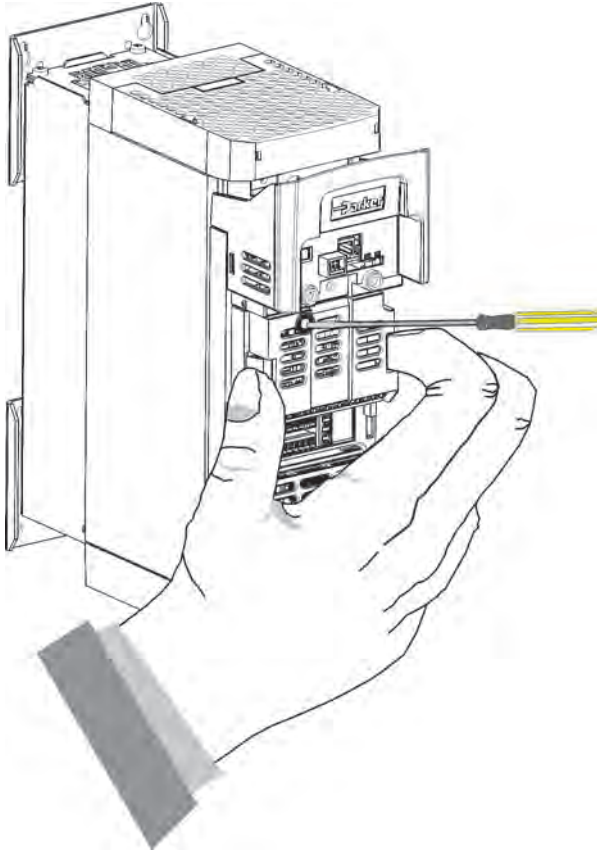

7. Slide and click back the VCM lower cover, tighten the retaining screw and slot back the GKP.

# 4

## User Terminals

---

The encoder option module contains blocks of user terminals, as shown below.

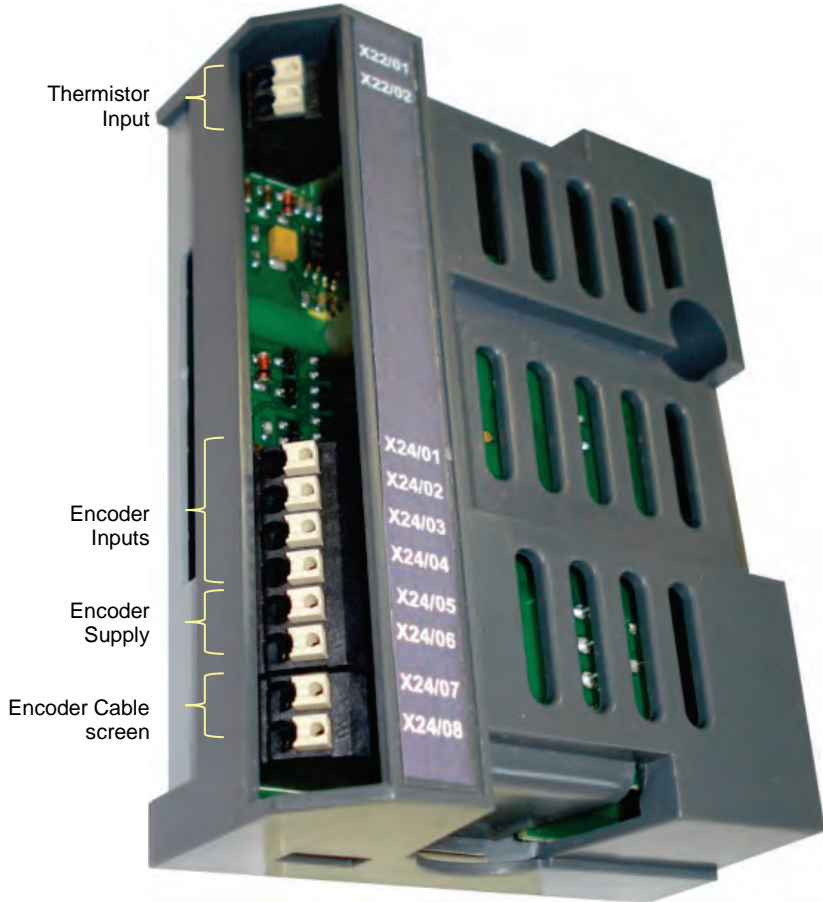

## User Wiring

---

### Terminal Cable Specification

Solid minimum H05(07)V-U 0.2sqmm.

Solid maximum H05(07)V-U 1.5 sqmm.

Flexible minimum H05(07)V-K 0.2 sqmm.

Flexible maximum H05(07)V-K 1.5 sqmm.

W.wire end Ferrule DIN462228 Pt 1 minimum 0.25 sqmm.

W.wire end Ferrule DIN462228 Pt 1 maximum 1.5 sqmm.

W.plastic collar Ferrule DIN462228 Pt4 minimum 0.25 sqmm (see note 1)

W.plastic collar Ferrule DIN462228 Pt4 maximum 0.75 sqmm (see note 2).

*Note 1: Parker SSD part number CI053612U001 (Davico part No. PET0505)*

*Note 2: Parker SSD part number CI053612U002 (Davico part No. PET7575).*

# 6

## Motor Thermistor

---

The motor thermistor input provides a means of monitoring motor temperature in order to protect the motor from a potentially damaging high temperature.

By default the drive will trip if the motor exceeds a user-defined temperature threshold thereby preventing the motor temperature from rising further.

Once tripped, the user can attempt to reset the trip at any time. However if the motor temperature is still above the trip threshold, the trip cannot be reset.

Refer to the Chapter 10 in the AC30V product manual (HA501718U002) for information on trips, possible causes, and how to reset them. A motor thermistor fault is identified in that manual as ID13 (Motor Overtemp).

Terminal		Name	Range	Description
X22	01	TH1	0Ω to 4500Ω	Connect motor thermistor between these two terminals. If a thermistor is not required, connect these two terminals together, and ensure PTC thermistor is selected in parameter 1184.
	02	TH2		

## Programming

Parameter Name (PNO)	Access	Value	Description
Thermistor Type (1184)	Write or Read	NTC PTC KTY	Thermistor type. Default = PTC
Thermistor Resistance (1185)	Read only	0 to 5000Ω	Measured thermistor resistance.
			0Ω The thermistor measurement is invalid. Probably caused by a faulty encoder board.
			1Ω to 4500Ω The thermistor measurement is valid. Note - A short circuit thermistor reports a small non-zero value.
		5000Ω	The thermistor is open-circuit or the measurement is invalid.
Thermistor Trip Level (1004)	Write or Read	0 to 4500Ω	Thermistor trip level. Default = 1000Ω
			NTC The drive trips if the thermistor resistance is less than this trip level.
			PTC or KTY The drive trips if the thermistor resistance exceeds this trip level.

## Specification

Thermistor resistance measurement range	0 to 4500Ω
Resistance measurement accuracy	±5%
Thermistor compatibility	NTC, PTC, KTY Default = PTC
Measurement supply voltage	1.3V @ 1kΩ
Motor temperature trip threshold	Resistance threshold set by user. Default = 1000Ω.
Update rate	1 second
Insulation	Reinforced insulation between thermistor terminals and drive electronics.



### Important safety information:

Insulation and routing of wiring to the thermistor terminals must be appropriately rated to ensure the correct degree of insulation to other user wiring.

## Example Application

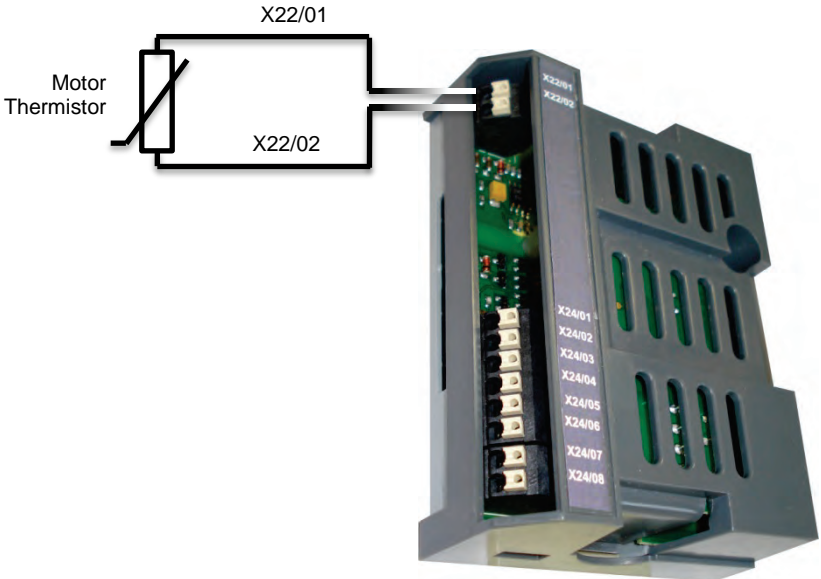

## Incremental Pulse Encoder

The incremental pulse encoder feature enables closed-loop speed control in the AC30V range of drives. An incremental pulse encoder provides position feedback to the drive relative to an arbitrary starting position. The drive's processor can use the encoder position history to calculate motor speed.

Encoders are available in many forms, both mechanically and electrically. The mechanical form is selected by the user according to the application. The electrical form should be chosen to be compatible with the 7004-04-00. Suitable encoders will conform to the specification below:

Feature	Value	
Supply Voltage	5V, 12V, 15V or 24V	
Unloaded Supply Current Consumption (i.e. outputs are disconnected)	< 300mA @ 5V < 210mA @ 12V < 160mA @ 15V < 100mA @ 24V	
Output signaling	Differential or single-ended	
Output signaling level	Differential	$\pm 3V$ to $\pm 24V$ , which includes: TTL RS422 RS485 HTL (10V to 30V)
	Single-ended	HTL (10V to 24V)
Output sequencing	Two channels, in quadrature or clock and direction	
Maximum pulse frequency	$\leq 250\text{kHz}$ per channel	
Duty cycle (each channel)	50% $\pm$ 10%	
Quadrature (except in clock and direction mode)	$90^\circ \pm 45^\circ$	

# 10

## Encoder Inputs

The Encoder Option Module 7004-04-00 provides user terminals for connecting to encoder outputs. A wide specification allows it to be used with a wide variety of encoders from different manufacturers.

Terminal	Name	Range	Description	
X24	01	Channel A	Encoder inputs, compatible with a wide range of encoders.  The user can program the inputs to be differential or single-ended, and quadrature or clock (channel A) and direction (channel B).	
	02	Channel /A		
	03	Channel B		
	04	Channel /B		
	05	SUPPLY POSITIVE	Selectable 5V, 12V, 15V and 24V	Software-selectable power supply output to encoder.
	06	SUPPLY NEGATIVE		
	07	CABLE SCREEN		
	08			



## Programming

Parameter Name (PNO)	Access	Bit	Value	Description
Encoder Lines (1512)	Write or Read	0.. 16	1 to 100000	The number of encoder lines per revolution (default = 1024)
Encoder Invert (1513)	Write or Read	0	0	Encoder direction is normal (default)
			1	Encoder direction is inverted.
Encoder Type (1514)	Write or Read	0	0	Encoder inputs are quadrature (default)
			1	Encoder inputs are clock (channel A, /A) and direction (B, /B)
Single-ended (1515)	Write or Read	0	0	Encoder inputs are differential (default)
			1	Encoder inputs are single-ended
Encoder Count Reset (1517)	Write or Read	0	0	No effect
			1	Forces the encoder count (PNO 1518) to zero
Encoder Speed (1516)	Read only		$0 \pm 100000$	Measured encoder speed in RPM
Encoder Count (1518)	Read only		$-2^{31}$ to $+ (2^{31} - 1)$	<p>In quadrature mode, this value increments or decrements by 4 for every encoder line.</p> <p>In clock and direction mode, this value increments or decrements by 1 for every encoder line.</p> <p>The value resets to zero on power-up, or when Encoder Count Reset (PNO 1517) = 1.</p>

# 12

## Power Supply

The Encoder Option Module 7004-04-00 provides a power supply for powering the encoder. The supply voltage can be selected from a range allowing use with a wide range of encoders.

Terminal	Name	Range	Description	
X24	01	Channel A	Encoder inputs, compatible with a wide range of encoders.  The user can program the inputs to be differential or single-ended.	
	02	Channel /A		
	03	Channel B		
	04	Channel /B		
	05	SUPPLY POSITIVE	Selectable 5V, 12V, 15V and 24V	Software-selectable power supply output to encoder.
	06	SUPPLY NEGATIVE		
	07	CABLE SCREEN		
	08			

Note 1:

The encoder power supply is fully isolated, from the drive's internal circuits, and from the encoder inputs on X24 terminals 01 to 04.

Note 2:

In some applications that have a long cable between drive and encoder, the supply voltage drop along the cable may become excessive, and the voltage received at the encoder might drop below the encoder's specification. This is most likely with 5V encoders. In this case, the user should provide a local power supply, or choose an encoder with a wider supply range.

## Programming

The encoder supply voltage can be set by parameter 1511,

Parameter Name (PNO)	Access	Bit	Value	Description
Encoder Supply (1511)	Write or Read	00 to 01	0	Encoder supply voltage = 5V (default)
			1	Encoder supply voltage = 12V
			2	Encoder supply voltage = 15V
			3	Encoder supply voltage = 24V

Note 3:

Where encoders support supplies within the range 8V to 30V, the voltage should normally be set as high as possible to improve noise immunity.

## Specification

Feature	Value	
Supply output voltage	User selectable 5V, 12V, 15V, 24V	
Output voltage accuracy	5V	Minimum = 5.02V Typical = 5.15V Maximum = 5.27V
	12V, 15V, 24V	±7%
Typical current capacity	5V	Typical 450mA. Guaranteed 300mA
	12V	Typical 350mA. Guaranteed 210mA
	15V	Typical 280mA. Guaranteed 160mA
	24V	Typical 175mA. Guaranteed 100mA
Fault protection	No damage will be caused by overload or short circuit. It may be necessary to cycle power to the drive or temporarily disconnect the encoder to recover from a fault.	
Isolation	The encoder supply is galvanically isolated from the drive and from the encoder input terminals. Isolation is functional only, intended to eliminate ground loops. It is not a safety isolation barrier.	

## Cable Screen Connection

Terminals X24/07 and X24/08 are for connection to the encoder cable screen. Either one or both terminals can be used; they are connected together internally.

Terminal	Name	Range	Description	
X24	01	Channel A	Encoder inputs, compatible with a wide range of encoders.  The user can program the inputs to be differential or single-ended.	
	02	Channel /A		
	03	Channel B		
	04	Channel /B		
	05	SUPPLY POSITIVE	Selectable 5V, 12V, 15V and 24V	Software-selectable power supply output to encoder.
	06	SUPPLY NEGATIVE		
	07	CABLE SCREEN		
	08			

### Important notes:

In order to meet the Electro-Magnetic Compatibility (EMC) specification, both the motor screen and encoder screen should both be connected directly at the motor and drive, and not interrupted.

If the motor cable screen is not continuous or not connected directly at the motor and drive, earth currents that should return to the drive through the motor cable screen may instead return via the encoder cable screen, and unreliable encoder operation may result.

If it is not possible for the motor cable screen to be continuous or not connected directly at the motor or drive, encoder reliability may be improved by disconnecting the encoder cable screen, preferably at the encoder. In this case, it is the user's responsibility to ensure the system works reliably.

### Differential or Single-Ended Signalling

Differential signalling is the preferred connection method, especially in noisy environments or where the transmission distance is long.

#### Differential Signaling Connections (PNO 1515 = 0)

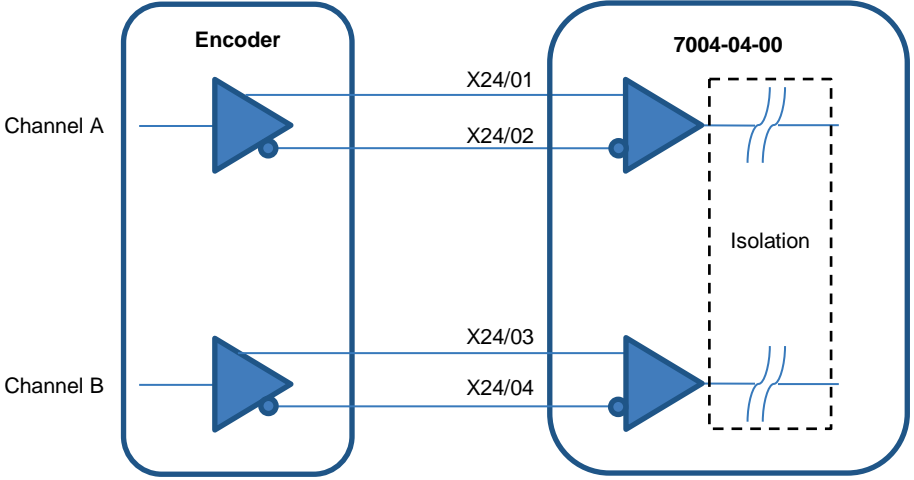

#### Single-Ended Signaling Connections (PNO 1515 = 1)

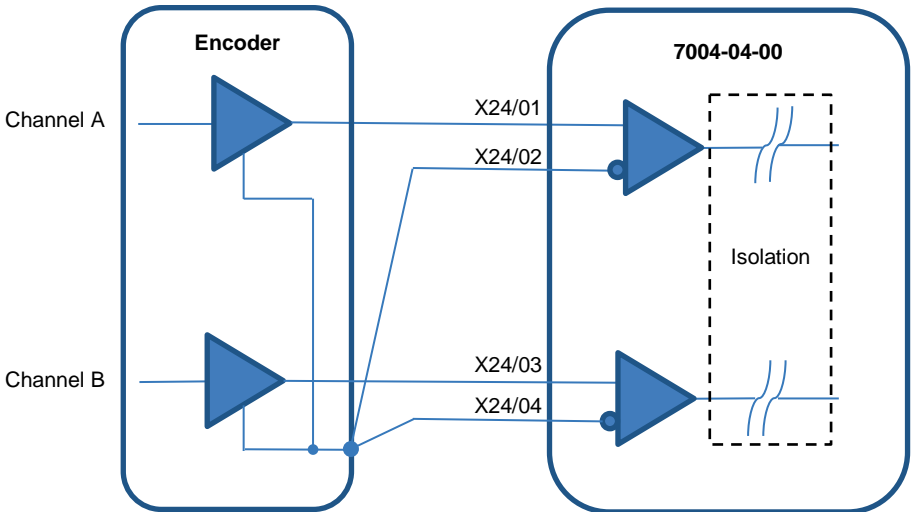

## Example Applications

The following pages show the relationship between signal inputs of different types, the Encoder Type and Encoder Invert.

**Encoder Type = Quadrature (PNO 1514 = 0)**

**Encoder Invert = False (PNO 1513 = 0)**

If Channel A leads Channel B, the encoder is considered to be rotating clockwise. If Channel B leads Channel A, the encoder is considered to be rotating anti-clockwise.

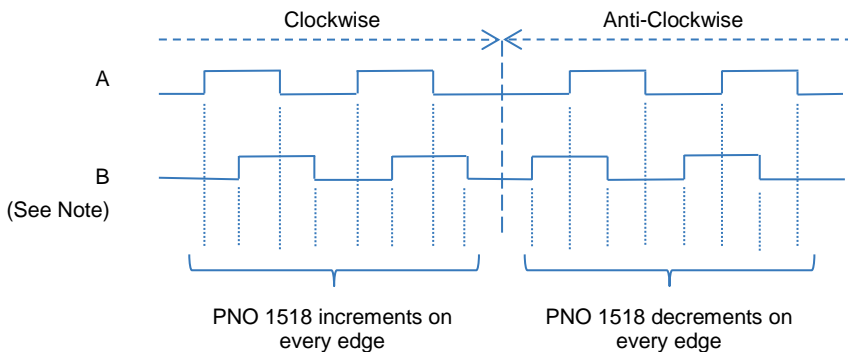

Note:

A = Channel A relative to Channel /A

B = Channel B relative to Channel /B

# 18

**Encoder Type = Clock / Direction (PNO 1514 = 1)**  
**Encoder Invert = False (PNO 1513 = 0)**

If Channel B is low, the encoder is considered to be rotating clockwise. If Channel B is high, the encoder is considered to be rotating anti-clockwise.

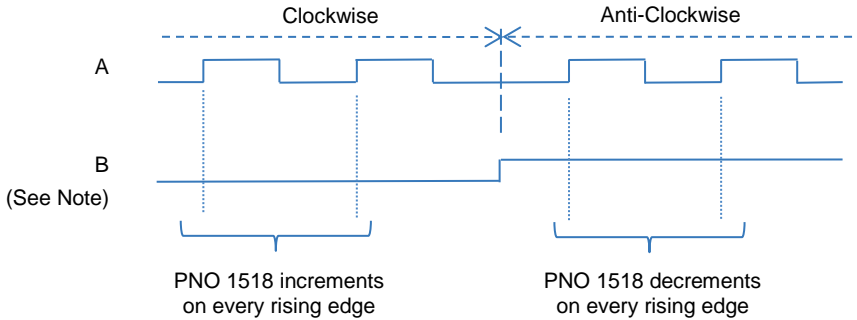

Note:

A = Channel A relative to Channel /A

B = Channel B relative to Channel /B



**Encoder Type = Quadrature (PNO 1514 = 0)**

**Encoder Invert = True (PNO 1513 = 1)**

If Channel A leads Channel B, the encoder is considered to be rotating anti-clockwise. If Channel B leads Channel A, the encoder is considered to be rotating clockwise.

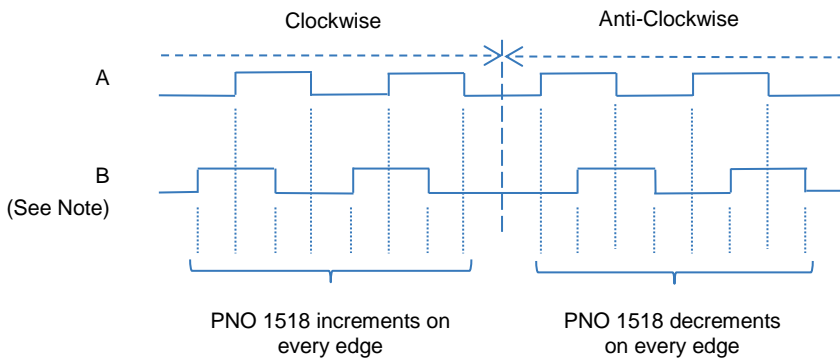

Note:

A = Channel A relative to Channel /A

B = Channel B relative to Channel /B

# 20

**Encoder Type = Clock and Direction (P 1514 = 1)**  
**Encoder Invert = True (PNO 1513 = 1)**

If Channel B is high, the encoder is considered to be rotating clockwise. If Channel B is low, the encoder is considered to be rotating anti-clockwise.

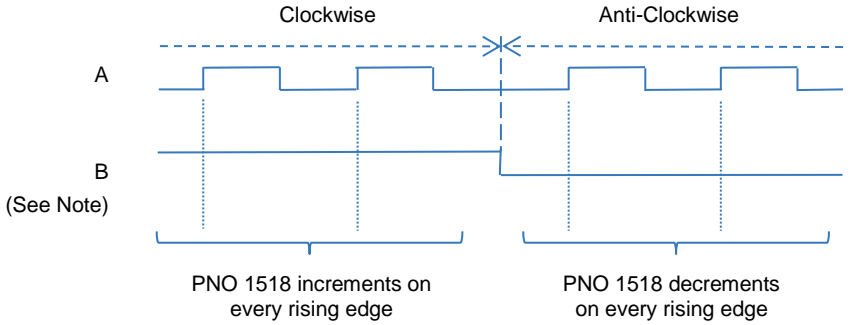

Note:

A = Channel A relative to Channel /A

B = Channel B relative to Channel /B

## Specification

Feature	Value	
Absolute maximum input voltage (A relative to /A and B relative to /B)	±30V	
Recommended input voltage range (A relative to /A and B relative to /B)	Differential	±3V to ± 24V
	Single-ended	0 to +24V
Input current	≤10mA per channel	
Input threshold voltage (typical)	Differential	+2V and -2V
	Single-ended	+7V
Input Hysteresis (typical)	Differential	4V centred at 0V
	Single-ended	None
Maximum pulse rate per channel	250kHz	
Isolation	The encoder inputs are galvanically isolated from the drive, from each other and from the encoder supply. Isolation is functional only, intended to eliminate ground loops. It is not a safety isolation barrier.	

## Encoder Cable

The ideal cable should have:

- Three twisted pairs (one pair each for power supply, Channel A and Channel B)
- Each pair individually screened
- Overall shield
- Characteristic impedance 100Ω to 130Ω
- Maximum cable length of 50m

e.g. Belden 8163

With 5V encoders in particular, voltage drop on the supply should be considered, and the wire gauge and cable length chosen appropriately. If necessary, a local power supply should be provided.

Wire gauge can be estimated from:

$$\text{Resistance / metre} \leq \frac{\text{Supply Voltage} - \text{Encoder Voltage}}{2 \times \text{Cable Length} \times \text{Current}}$$

Where:

*Resistance / metre = individual conductor resistance per metre*

*Supply Voltage = 5.02V<sup>1</sup>*

*Encoder Voltage = minimum supply voltage required by the 5V encoder*

*Cable length from encoder to 7004-04-00, measured in metres*

*Current = Current drawn by the encoder in amps*

*= Unloaded current from encoder specification + 20mA*

Example:

Encoder voltage = 5.00V ± 5% = 4.75V minimum

Cable length = 10 metres

Unloaded current = 150mA

$$\begin{aligned} \text{Conductor Resistance} &\leq \frac{5.02 - 4.75}{2 \times 10 \times 0.17} \\ &= 0.079\Omega / \text{metre} \end{aligned}$$

---

<sup>1</sup> Assuming 5V supply is selected, the minimum output = 5.02V.

## Recommended Encoders

---

The following encoders have been tested and approved for use with the 7004-04-00:

## Setting up Closed Loop Operation

---

Please refer to the AC30V user manual HA501718U001 for information on setting up and running the drive in closed loop operation using encoder feedback.

## Environmental

---

### **Registration, Evaluation, Authorisation and Restriction of Chemicals (REACH)**

The Regulation (EC) No 1907/2006 of the European Parliament and of the Council of 18 December 2006 concerning the Registration, Evaluation, Authorization, and Restriction of Chemicals (REACH) entered into force on June 1, 2007. Parker agrees with the purpose of REACH which is to ensure a high level of protection of human health and the environment. Parker is compliant with all applicable requirements of REACH.

The registration requirements do not apply to Parker since it is neither a manufacturer nor an importer of preparations into Europe.

However, product (article) manufacturers or importers into Europe are obligated under Article 33 of REACH to inform recipients of any articles that contain chemicals on the Substances of Very High Concern (SVHC) candidate list above a 0.1% concentration (by weight per article). As of 19<sup>th</sup> December 2011 VSD products manufactured and marketed by Parker do not contain substances on the REACH SVHC candidate list in concentrations greater than 0.1% by weight per article. Parker will continue to monitor the developments of the REACH legislation and will communicate with our customers according to the requirement above.

### **Restriction of Hazardous Substances (RoHS)**

This product is in full compliance with RoHS Directive 2011/65/EU, with respect to the following substances:

- 1) Lead (Pb),
- 2) Mercury (Hg),
- 3) Cadmium (Cd),
- 4) Hexavalent chromium (Cr (VI)),
- 5) Polybrominated biphenyls (PBB),
- 6) Polybrominated diphenyl ethers (PBDE).

## Waste Electrical and Electronic Equipment (WEEE)



Waste Electrical and Electronic Equipment - must not be disposed of with domestic waste.

It must be separately collected according to local legislation and applicable laws.

Parker Hannifin Company, together with local distributors and in accordance with EU directive 2002/96/EC, undertakes to withdraw and dispose of its products, fully respecting environmental considerations.

For more information about how to recycle your Parker supplied waste equipment, please contact your local Parker Service Centre.

## Packaging

During transport our products are protected by suitable packaging. This is entirely environmentally compatible and should be taken for central disposal as secondary raw material.



# Parker Worldwide

**AE – UAE, Dubai**  
Tel: +971 4 8127100  
parker.me@parker.com

**AR – Argentina, Buenos Aires**  
Tel: +54 3327 44 4129

**AT – Austria, Wiener Neustadt**  
Tel: +43 (0)2622 23501-0  
parker.austria@parker.com

**AT – Eastern Europe, Wiener Neustadt**  
Tel: +43 (0)2622 23501 900  
parker.eastereurope@parker.com

**AU – Australia, Castle Hill**  
Tel: +61 (0)2-9634 7777

**AZ – Azerbaijan, Baku**  
Tel: +994 50 2233 458  
parker.azerbaijan@parker.com

**BE/LU – Belgium, Nivelles**  
Tel: +32 (0)67 280 900  
parker.belgium@parker.com

**BR – Brazil, Cachoeirinha RS**  
Tel: +55 51 3470 9144

**BY – Belarus, Minsk**  
Tel: +375 17 209 9399  
parker.belarus@parker.com

**CA – Canada, Milton, Ontario**  
Tel: +1 905 693 3000

**CH – Switzerland, Etoy**  
Tel: +41 (0)21 821 87 00  
parker.switzerland@parker.com

**CL – Chile, Santiago**  
Tel: +56 2 623 1216

**CN – China, Shanghai**  
Tel: +86 21 2899 5000

**CZ – Czech Republic, Klecany**  
Tel: +420 284 083 111  
parker.czechrepublic@parker.com

**DE – Germany, Kaarst**  
Tel: +49 (0)2131 4016 0  
parker.germany@parker.com

**DK – Denmark, Ballerup**  
Tel: +45 43 56 04 00  
parker.denmark@parker.com

**ES – Spain, Madrid**  
Tel: +34 902 330 001  
parker.spain@parker.com

**FI – Finland, Vantaa**  
Tel: +358 (0)20 753 2500  
parker.finland@parker.com

**FR – France, Contamine s/Arve**  
Tel: +33 (0)4 50 25 80 25  
parker.france@parker.com

**GR – Greece, Athens**  
Tel: +30 210 933 6450  
parker.greece@parker.com

**HK – Hong Kong**  
Tel: +852 2428 8008

**HU – Hungary, Budapest**  
Tel: +36 1 220 4155  
parker.hungary@parker.com

**IE – Ireland, Dublin**  
Tel: +353 (0)1 466 6370  
parker.ireland@parker.com

**IN – India, Mumbai**  
Tel: +91 22 6513 7081-85

**IT – Italy, Corsico (MI)**  
Tel: +39 02 45 19 21  
parker.italy@parker.com

**JP – Japan, Tokyo**  
Tel: +81 (0)3 6408 3901

**KR – South Korea, Seoul**  
Tel: +82 2 559 0400

**KZ – Kazakhstan, Almaty**  
Tel: +7 7272 505 800  
parker.eastereurope@parker.com

**MX – Mexico, Apodaca**  
Tel: +52 81 8156 6000

**MY – Malaysia, Shah Alam**  
Tel: +60 3 7849 0800

**NL – The Netherlands, Oldenzaal**  
Tel: +31 (0)541 585 000  
parker.nl@parker.com

**NO – Norway, Asker**  
Tel: +47 66 75 34 00  
parker.norway@parker.com

**NZ – New Zealand, Mt Wellington**  
Tel: +64 9 574 1744

**PL – Poland, Warsaw**  
Tel: +48 (0)22 573 24 00  
parker.poland@parker.com

**PT – Portugal, Leca da Palmeira**  
Tel: +351 22 999 7360  
parker.portugal@parker.com

**RO – Romania, Bucharest**  
Tel: +40 21 252 1382  
parker.romania@parker.com

**RU – Russia, Moscow**  
Tel: +7 495 645-2156  
parker.russia@parker.com

**SE – Sweden, Spånga**  
Tel: +46 (0)8 59 79 50 00  
parker.sweden@parker.com

**SG – Singapore**  
Tel: +65 6887 6300

**SK – Slovakia, Banská Bystrica**  
Tel: +421 484 162 252  
parker.slovakia@parker.com

**SL – Slovenia, Novo Mesto**  
Tel: +386 7 337 6650  
parker.slovenia@parker.com

**TH – Thailand, Bangkok**  
Tel: +662 717 8140

**TR – Turkey, Istanbul**  
Tel: +90 216 4997081  
parker.turkey@parker.com

**TW – Taiwan, Taipei**  
Tel: +886 2 2298 8987

**UA – Ukraine, Kiev**  
Tel: +380 44 494 2731  
parker.ukraine@parker.com

**UK – United Kingdom, Warwick**  
Tel: +44 (0)1926 317 878  
parker.uk@parker.com

**US – USA, Cleveland**  
Tel: +1 216 896 3000

**VE – Venezuela, Caracas**  
Tel: +58 212 238 5422

**ZA – South Africa, Kempton Park**  
Tel: +27 (0)11 961 0700  
parker.southafrica@parker.com

**European Product Information Centre**

**Free phone: 00 800 27 27 5374**

**(from AT, BE, CH, CZ, DE, EE, ES, FI, FR, IE, IL, IS, IT, LU, MT, NL, NO, PT, SE, SK, UK)**

© 2012 Parker Hannifin Corporation. All rights reserved.

**Parker Hannifin Manufacturing Limited,  
Automation Group, SSD Drives Europe,**  
New Courtwick Lane, Littlehampton,  
West Sussex BN17 7RZ  
United Kingdom  
Tel: +44(0)1903 737000  
Fax: +44(0)1903 737100  
www.parker.com/ssd



\* H A 5 0 2 2 1 7 0 0 1 0 2 \*