

aerospace  
climate control  
**electromechanical**  
filtration  
fluid & gas handling  
hydraulics  
pneumatics  
process control  
sealing & shielding

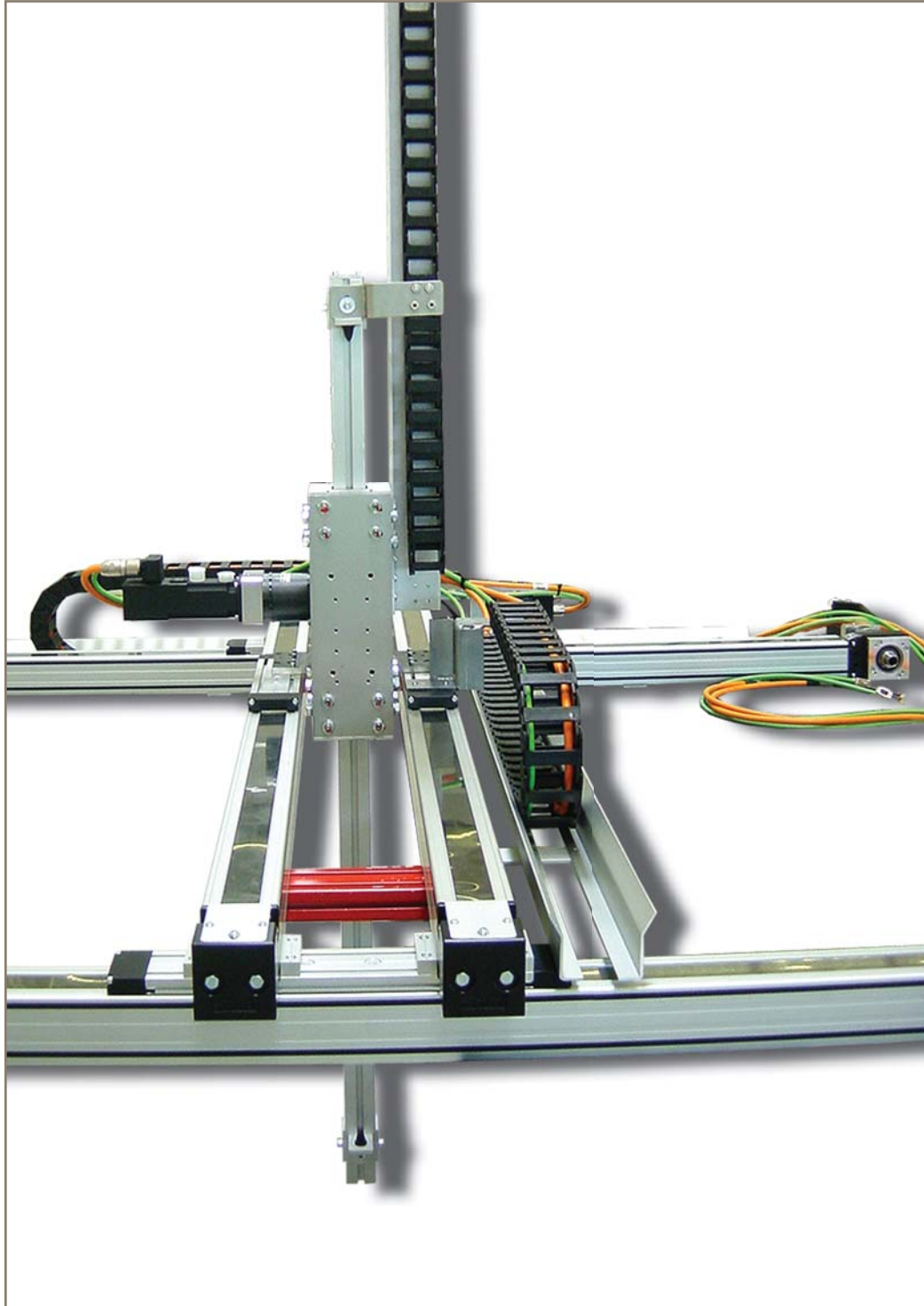

# Standard Gantry Robots

Standard System



ENGINEERING YOUR SUCCESS.



**WARNING – USER RESPONSIBILITY**

**FAILURE OR IMPROPER SELECTION OR IMPROPER USE OF THE PRODUCTS DESCRIBED ITEMS CAN CAUSE DEATH;  
PERSONAL INJURY AND PROPERTY DAMAGE.**

- This document and other information from Parker-Hannifin Corporation, its subsidiaries and authorized distributors provide product or system options for further investigation by users having technical expertise.
- The user, through its own analysis and testing, is solely responsible for making the final selection of the system and components and assuring that all performance, endurance, maintenance, safety and warning requirements of the application are met. The user must analyze all aspects of the application,
- follow applicable industry standards, and follow the information concerning the product in the current product catalog and in any other materials provided from Parker or its subsidiaries or authorized distributors.
- To the extent that Parker or its subsidiaries or authorized distributors provide component or system options based upon data or specifications provided by the user, the user is responsible for determining that such data and specifications are suitable and sufficient for all applications and reasonably foreseeable uses of the components or systems.

## Content

<b>Electromechanical Automation .....</b>	<b>5</b>
Global Products with local manufacturing and support .....	6
<b>With Standard to the Custom Gantry.....</b>	<b>6</b>
<b>Standard Line Gantry: .....</b>	<b>8</b>
Technical specifications .....	8
Dimensions .....	9
<b>Standard Space Gantry:.....</b>	<b>10</b>
Technical specification .....	10
Dimensions .....	11
<b>Energy Chains: .....</b>	<b>12</b>
Dimensions for support and cable carrier chain .....	12
<b>Drive Package .....</b>	<b>13</b>
<b>Gantries - Overview.....</b>	<b>14</b>
<b>Order code.....</b>	<b>15</b>



# Electromechanical Automation

## Global Products with Local Manufacturing and Support

### Global Product Design

Since 1963 PARKER Hannifin has extensive experiences in the design and manufacturing of drives, controls, motors and mechanical products. With dedicated global product development teams, Parker draws on industry-leading technological leadership and experience from engineering teams in Europe, North America and Asia.

### Local Application Expertise

Parker has local engineering resources committed to adapting and applying our current products and technologies to best fit our customers' needs. Parker's engineering resources also extend to the development and manufacturing of complete systems for continuous process and motion control applications.

### Manufacturing to Meet our Customers' Needs

Parker is committed to meeting the increasing service demands that our customers require to succeed in the global industrial market. Parker's manufacturing teams seek continuous improvement through the implementation of lean manufacturing methods throughout the process. We measure ourselves on meeting our customers' expectations of quality and delivery, not just our own. In order to meet these expectations, Parker operates and continues to invest in our manufacturing facilities in Europe, North America and Asia. This allows us to minimize transportation time and costs. And we are able to respond immediately to customer needs.

### Worldwide Electromechanical Automation Manufacturing Locations

#### Europe

Littlehampton, GB  
Dijon, France  
Offenburg, Germany  
Milano, Italy

#### Asia:

Shanghai, China  
Chennai, India

#### North America

Rohnert Park, California  
Irwin, Pennsylvania  
Wadsworth, Ohio  
Charlotte, North Carolina  
New Ulm, Minnesota

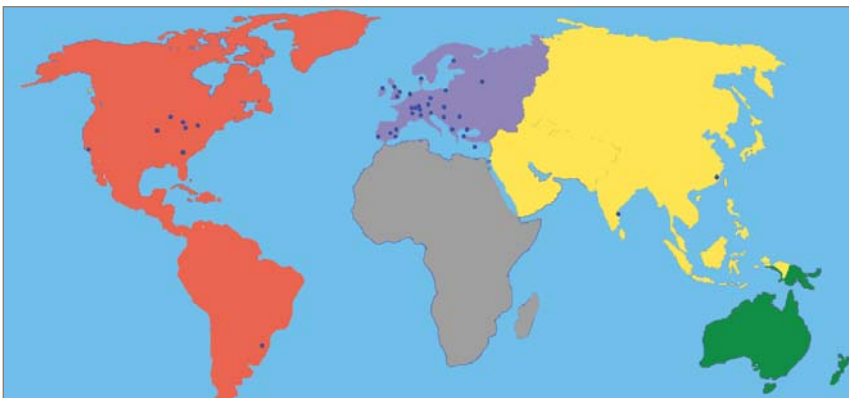

● Parker plants worldwide

Since 50 years, PARKER develops and produces high quality components and systems for the automation industry. Integrating development, production and service synergy for highest economic efficiency is effectively exploited. Technical innovation and future-orientated concepts are linked efficient with practical suitable solutions. The consequent followed systems idea enables an extensive palette of reasonable standardized automation solutions. Inherent handling systems for core industry, palletizing robots, linear - portals and space gantries, storage and retrieval machines, pick and place handling and charging gantries.

# With Standard to the Custom Gantry

## Gantry out of the box

### Standard components to satisfy your system requirements

Focussed system configurations enable robot applications to be specified easily using our carefully selected standard components, reducing the time and resources needed by the integrator to specify the system.

### Short deliveries & competitive pricing

Using our engineering standard PARKER components enable gantry kits to be supplied cost effectively. Factory pre - assembly is no longer required as proven component configurations eliminate possible installation errors. This saves time and costs. This results in an extreme short delivery time combined with an attractive price.

### Flexible solution for experienced machine builders

We deliver a gantry robot kit. The assembly of the kit and further construction will be done on your own. This includes among others: connecting the gripper at the Z-axis, mounting and connecting the controller, safety requirements and the machine setup.

**On request we can supply customized systems, including gripper, cabinet, control and steel frame !**

Line gantry with X- and Z-axes or space gantry with X-, Y- and Z-axes (all actuators with gearbox), optional with steel strip cover for the X- and Y-axis (Protection class IP30), optional with cable management (for all axes).

### Basic gantry

The basic version includes the linear actuators, with mounted gearbox and assembly accessories.

Customer supplied motors can be specified <sup>1)</sup>.

### Complete with drive

In addition to the basic gantry a complete drive package can be ordered. Comprising of:

- Motor
  - Controller, power module, plug set
  - Motor- and feedback cables
  - Parameter list
- for all axes.

### Motor- and feedback cables

Pre-defined cable length offered.



### Motors

Parker servo motors with resolver feedback or with SinusCosinus Multiturn feedback (absolute value encoder - no initiators)

1) If a customer-specific gearbox is used the delivery time of the entire gantry robot may extend up to 6 weeks.

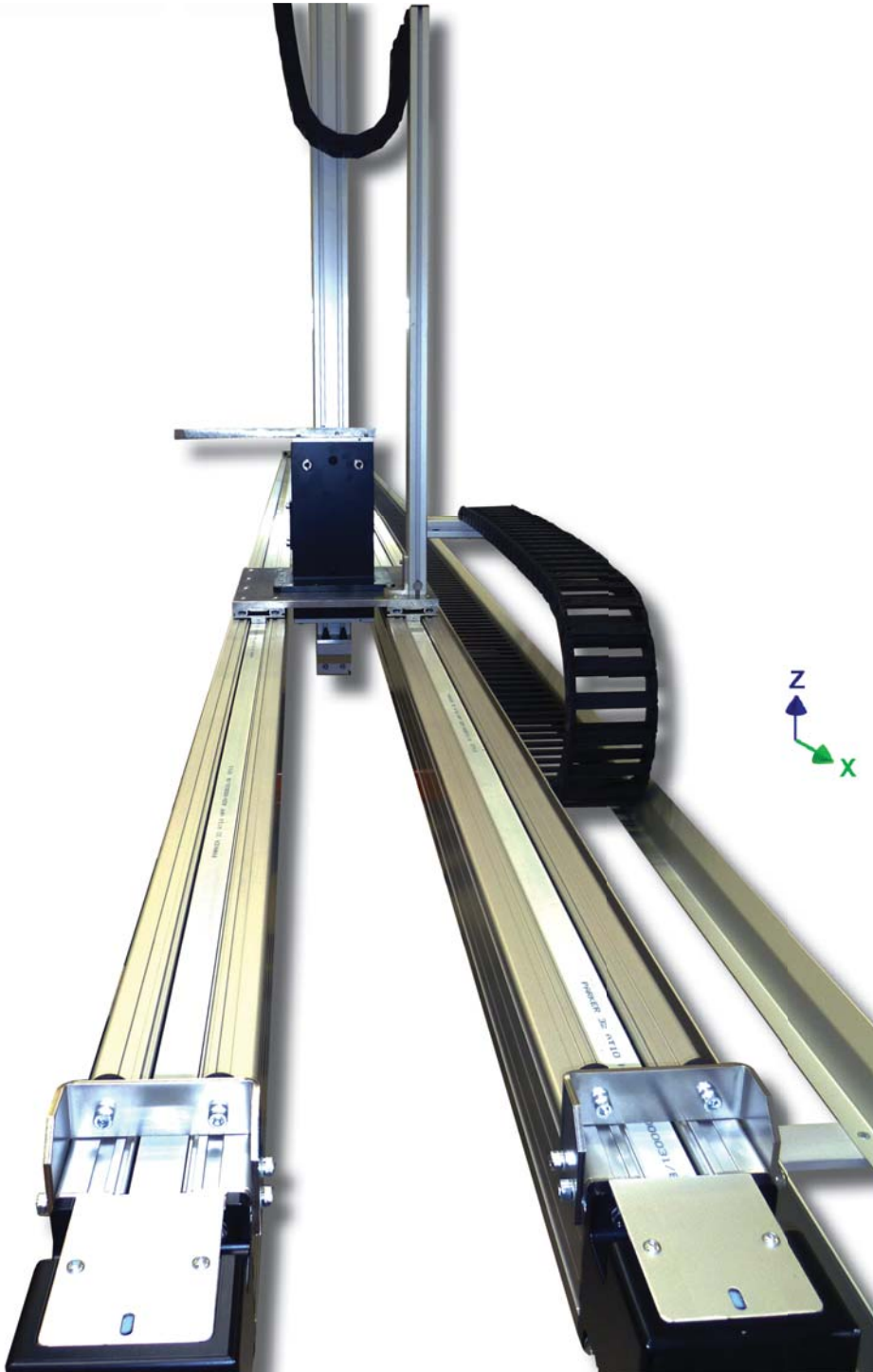

Fig. shows GL04 without steel frame

## Energy cable chain

This option provides standard-Energy cable chains for all axes of the device. The cable feed is located close to the x-axis drive.

## Controller

Compax3 provides a control solution to meet the most demanding requirements.



## Initiators and limit switch kit.

On request we deliver Initiators, end of travel switches and tripping plates for each axis (Please order separately). You will find ordering information in the related inear actuator catalogues:

## Steel frame

Steel support structures can be supplied on request for easy robot installation.

# Standard Linear Portal

Combination of LEB/LBB linear axis

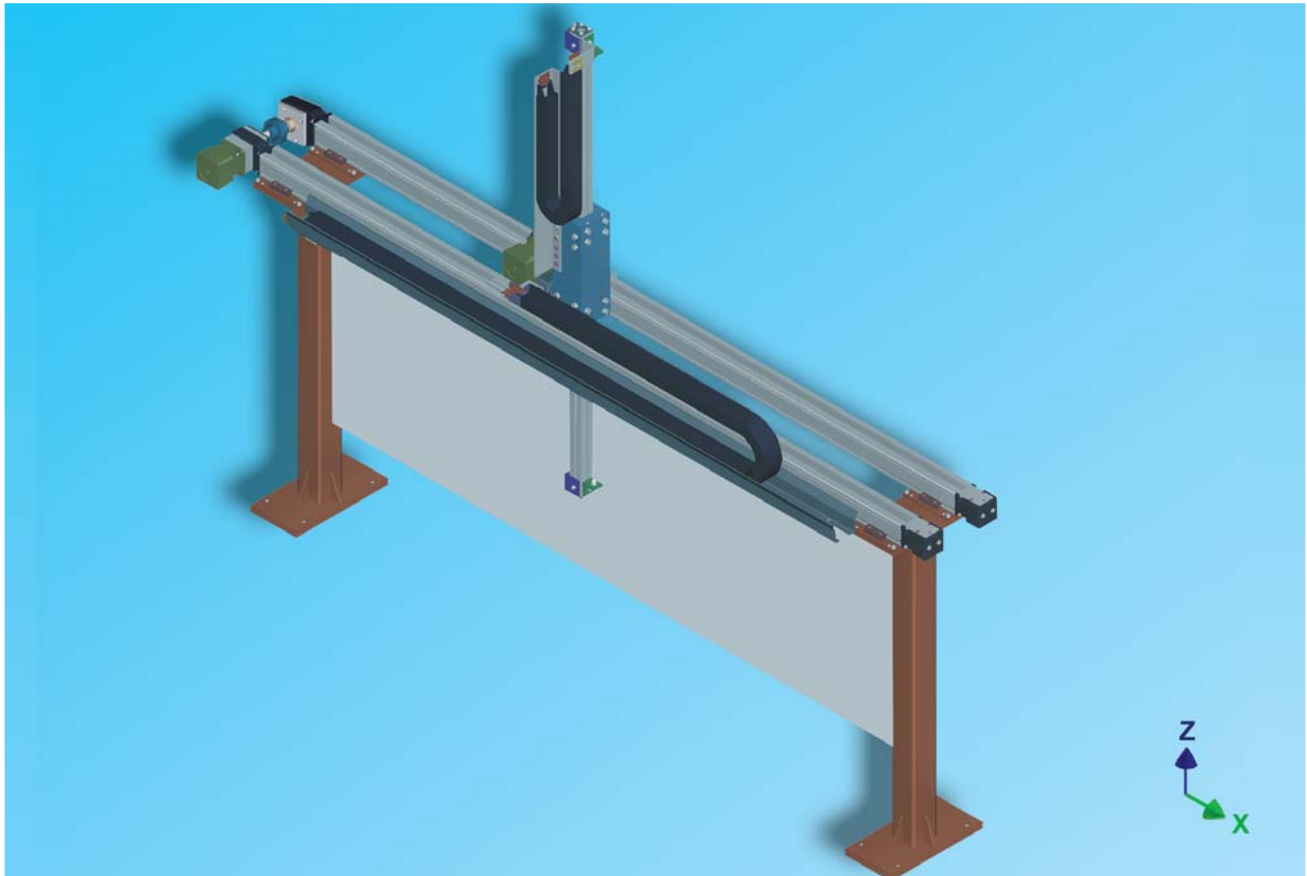

Fig. shows version with optional steel frame

Basic design							Drive			
Type	Axis	Module	max. hub	$V_{max}^{1)}$	$a_{max}^{2)}$	max. load	Gearing	$i^{3)}$	Motor <sup>4)</sup>	drive - package
			[m]	[m/s]	[m/s]	[kg]				
GL02	X	LBB080	5	2	3	60	PS90-007S2	7	SMH1004506519	GL2
	Z	ZEB050	1.5	1.5	5	30			SMHA1004506519	
GL03	X	LEB100	5.5	2	3	110	PS90-005S2	5	SMH1154010819	GL3
	Z	ZEB080	1.5	1.5	5	50	PS90-010S2	10	SMHA1154010819	
GL04	X	LBB120	8.5	2	3	130	PS90-007S2	7	SMH1154010819	GL4
	Z	ZEB080	1.5	1.5	4	75	PS90-010S2		SMHA1154010819	
GL05	X	LBB120	8.5	2	3	250	PS115-010S2	10	SMH1424515524	GL5
	Z	ZEB100	2	1.5	3	150			SMHA1424515524	

<sup>1)</sup> Value for maximum working width and maximum payload

<sup>2)</sup> Rated for X - axis, only during entered Z - axis

<sup>3)</sup> Gear ratio

<sup>4)</sup> SMH without brake, SMHA brake included



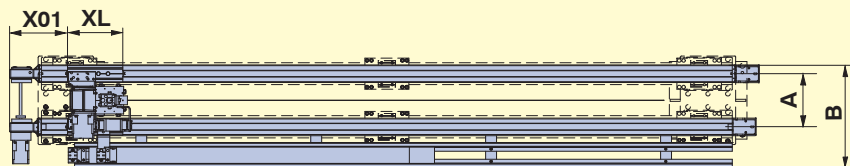
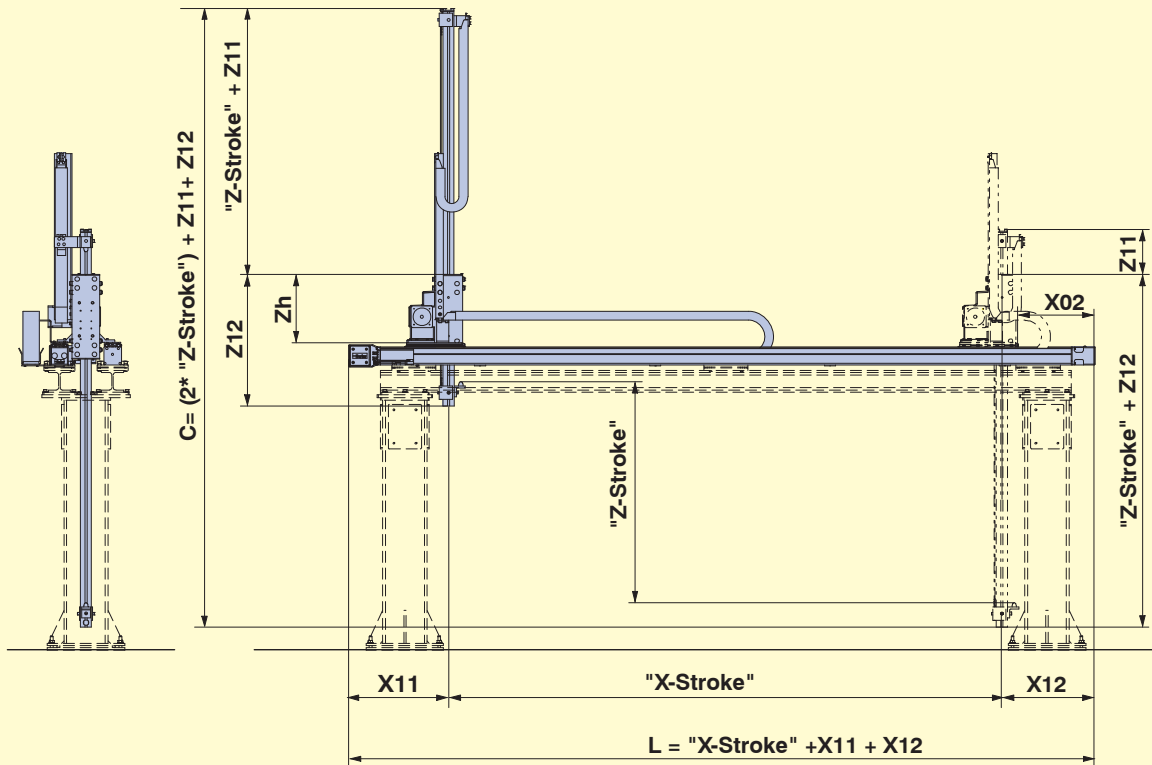

Line-Portal	Distance profile x-axis [mm]	Width [mm]	Length carriage [mm]	X-axis				Z-axis		
				Length for Safety distance [mm]		Length for Safety transcend [mm]		Length for distance transcend [mm]		Height housing [mm]
				1	2	1	2	1	2	
A	B	$X_L$	$X_{01}$	$X_{02}$	$X_{11}$	$X_{12}$	$Z_{11}$	$Z_{12}$	$Z_h$	
GL02	240	464	250	264	250	454	418	202	594	308
GL03	310	633	450	299	251	524	476	240	645	340
GL04	330	660	500	385	240	635	590	240	645	340
GL05	430	783	500	395	350	645	600	250	780	395

# Standard Space Gantry

Combination of LEB/LBB linear actuators and ZEB vertical axis

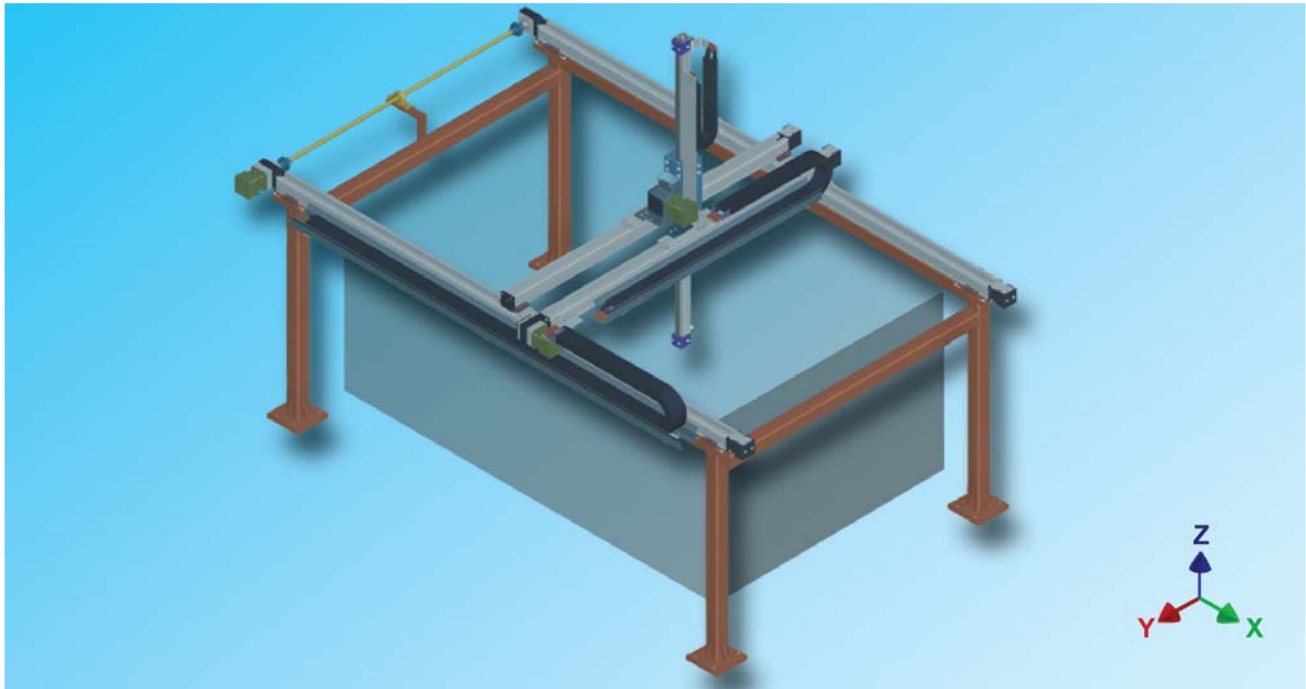

Fig. shows version with optional steel frame

Basic version							Drive			
Type	Axis	Module	max. hub [m]	$V_{max}^{1)}$ [m/s]	$a_{max}^{2)}$ [m/s]	max. load [kg]	Gearbox	$i^{3)}$	Motor <sup>4)</sup>	Drive package
GR02	X	LBB080	4.9	1.9	3.0	120	PS90-007S2	7	SMH 824503814	GR2
	Y	LBB080	2.0	1.9	3.0	60			SMH 824503814	
	Z	ZEB050	1.5	1.5	5.0	30			SMHA 824503814	
GR03	X	LEB100	5.5	2.0	3.0	210	PS90-005S2	5	SMH1154010819	GR3
	Y	LEB100	2.5	2.0	3.0	110			SMH1154010819	
	Z	ZEB080	1.5	1.5	5.0	50	PS90-010S2	10	SMHA1154010819	
GR06	X	LBB120	8.5	2.0	3.0	310	PS90-010S2	10	SMH1155610819	GR6
	Y	LBB120	3.9	2.0	3.0	130	PS90-007S2	7	SMH1154010819	
	Z	ZEB080	1.5	1.5	4.0	75	PS90-010S2	10	SMHA1154010819	
GR08	X	LBB120	8.5	2.0	3.0	400	PS115-010S2	10	SMH1424515524	GR8
	Y	LBB120	2.5	2.0	3.0	250			SMH1424515524	
	Z	ZEB100	2.0	1.5	3.0	150			SMHA1424515524	
GR10	X	LEB150	7.4	2.0	3.0	500	PS115-007S2	7	SMH1424515524	GR10
	Y	LEB150	3.5	2.0	3.0	250			SMH1424515524	
	Z	ZEB100	2.0	1.5	3.0	150	PS115-010S2	10	SMHA1424515524	

<sup>1)</sup> Value for maximum working width and maximum load

<sup>2)</sup> Rated for X - axis, only during entered Z - axis

<sup>3)</sup> Gear ratio

<sup>4)</sup> SMH without brake, SMHA brake included

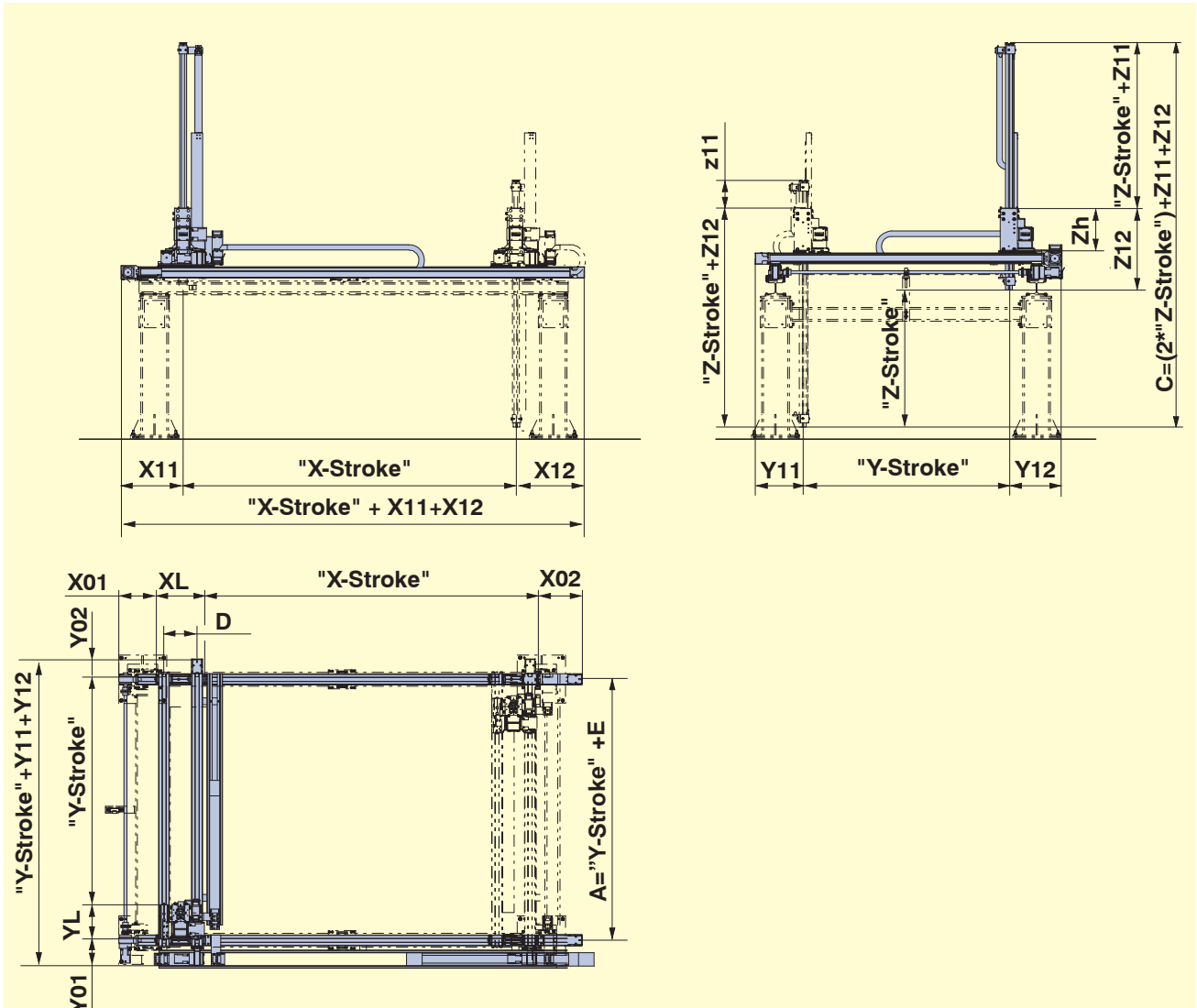

Line-Portal	Supplement distance profile x-axis [mm]	Distance profile Y-axis [mm]	Length carriage [mm]	X-axis				Y-axis				Length carriage [mm]	Z-axis			Height of casing [mm]
				Length for safety-stance [mm]		Length for safety-distance transcend [mm]		Length for safety-stance [mm]		Length for safety-distance transcend [mm]			Length for safety-distance transcend [mm]			
				1	2	1	2	1	2	1	2		1	2		
	E	D	X <sub>L</sub>	X <sub>01</sub>	X <sub>02</sub>	X <sub>11</sub>	X <sub>12</sub>	Y <sub>01</sub>	Y <sub>02</sub>	Y <sub>11</sub>	Y <sub>12</sub>	Y <sub>L</sub>	Z <sub>11</sub>	Z <sub>12</sub>	Z <sub>h</sub>	
GR02	400	240	400	271	201	454	418	197	285	348	384	250	202	594	308	
GR03	648	310	450	299	251	524	476	299	251	524	476	450	240	645	340	
GR06	580	330	500	385	340	635	590	285	240	535	490	500	240	645	340	
GR08	580	430	600	335	290	635	590	285	240	535	490	500	250	780	395	
GR10	670	400	600	358	270	658	570	358	270	608	520	500	250	780	395	

# Energy Chains

## Dimensions of Supporting Profile and E-chain

A cable carrier is needed when making power connections to moving elements. The cable carrier chain consists of Igu-mid® and the support profile is made of aluminum.

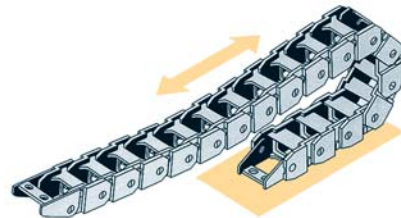
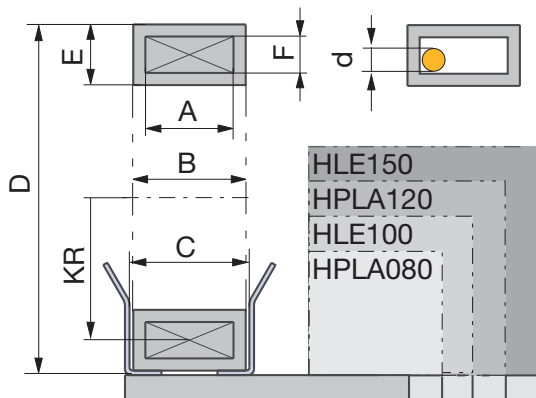
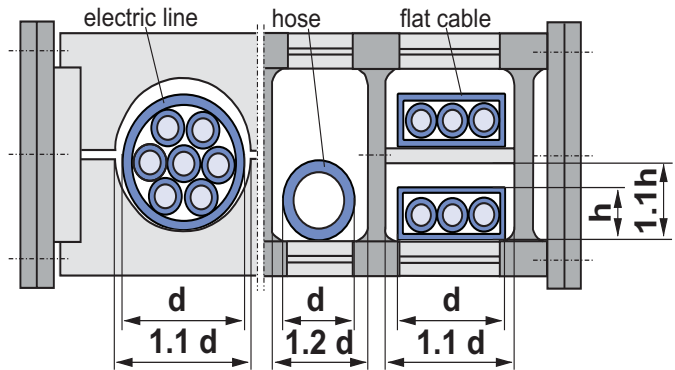
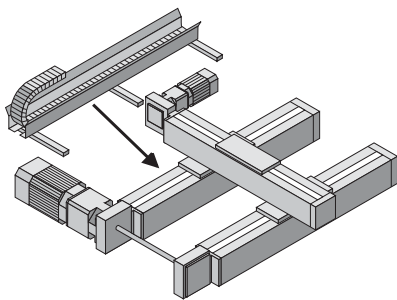

	Type	Bending radius KR	A	B	C	D max.	E	F	d max.	Art. No.	
										Cable carrier chain	Connection elements fix point and driving plate (inelastic)
[mm]											
with KSP1	B15.015.038.0	38	15	26	31	120	23	17.5	14	100-905150	100-905006
	B15.025.038.0	38	25	36	41	120	23	17.5	14	100-905170	100-905178
	2500.03.055.0	55	38	54	61	170	35	25	23	100-905810	100-905818
	2500.03.100.0	100	38	54	61	260	35	25	23	100-905830	100-905838
	2500.05.100.0	100	57	73	78	260	35	25	23	100-905850	100-905858
	2500.07.150.0	150	77	93	98	360	35	25	23	100-905860	100-905868
with KSP2	2700.07.200.0	200	75	91	96	485	50	35	32	100-905861	100-905869
	2700.12.200.0	200	125	141	146	485	50	35	32	100-905921	100-905928
	2700.17.200.0	200	175	194	199	485	50	35	32	100-905960	100-905968
KSP1 small cable supporting profile (Please state required length. Length = stroke)										400-010120	
KSP2 large cable supporting profile (Please state required length. Length = stroke)										400-010121	

# Drive Package

for Line- or Space - Gantries

Type	Servo drive		Signal cable				
	Compax 3M	Axis	Motor	Motor cable	Resolver	Multiturn Sinus-Cosinus-transducer	
GL2	C3 M050 D6 5.0A, 560/680 VDC	X	SMH1004506519	MOK 55/.. <sup>1)</sup>	REK42/.. <sup>1)</sup>	GBK24/.. <sup>1)</sup>	
	C3 M050 D6 5.0A, 560/680 VDC	Z	SMHA1004506519	MOK 54/.. <sup>1)</sup>	REK41/.. <sup>1)</sup>		
GL3	C3 M100 D6 10.0A, 560/680 VDC	X	SMH115401081	MOK 55/.. <sup>1)</sup>	REK42/.. <sup>1)</sup>		
	C3 M100 D6 10.0A, 560/680 VDC	Z	SMHA1154010819	MOK 54/.. <sup>1)</sup>	REK41/.. <sup>1)</sup>		
GL4	C3 M100 D6 10.0A, 560/680 VDC	X	SMH1154010819	MOK 55/.. <sup>1)</sup>	REK42/.. <sup>1)</sup>		
	C3 M100 D6 10.0A, 560/680 VDC	Z	SMHA1154010819	MOK 54/.. <sup>1)</sup>	REK41/.. <sup>1)</sup>		
GL5	C3 M100 D6 10.0A, 560/680 VDC	X	SMH1424515524	MOK 55/.. <sup>1)</sup>	REK42/.. <sup>1)</sup>		
	C3 M100 D6 10.0A, 560/680 VDC	Z	SMHA1424515524	MOK 57/.. <sup>1)</sup>	REK41/.. <sup>1)</sup>		
GR2	C3 M050 D6 5.0 A, 560/680 VDC	X	SMH 824503814	MOK 55/.. <sup>1)</sup>	REK42/.. <sup>1)</sup>		GBK24/.. <sup>1)</sup>
	C3 M050 D6 5.0 A, 560/680 VDC	Y	SMH 824503814	MOK 54/.. <sup>1)</sup>	REK41/.. <sup>1)</sup>		
	C3 M050 D6 5.0 A, 560/680 VDC	Z	SMHA 824503814	MOK 54/.. <sup>1)</sup>	REK41/.. <sup>1)</sup>		
GR3	C3 M100 D6 10.0A, 560/680 VDC	X	SMH1154010819	MOK 55/.. <sup>1)</sup>	REK42/.. <sup>1)</sup>		
	C3 M100 D6 10.0A, 560/680 VDC	Y	SMH1154010819	MOK 54/.. <sup>1)</sup>	REK41/.. <sup>1)</sup>		
	C3 M100 D6 10.0A, 560/680 VDC	Z	SMHA1154010819	MOK 54/.. <sup>1)</sup>	REK41/.. <sup>1)</sup>		
GR6	C3 M100 D6 10.0A, 560/680 VDC	X	SMH1155610819	MOK 55/.. <sup>1)</sup>	REK42/.. <sup>1)</sup>		
	C3 M100 D6 10.0A, 560/680 VDC	Y	SMH1154010819	MOK 54/.. <sup>1)</sup>	REK41/.. <sup>1)</sup>		
	C3 M100 D6 10.0A, 560/680 VDC	Z	SMHA1154010819	MOK 54/.. <sup>1)</sup>	REK41/.. <sup>1)</sup>		
GR8	C3 M100 D6 10.0 A, 560/680 VDC	X	SMH1424515524	MOK 55/.. <sup>1)</sup>	REK42/.. <sup>1)</sup>		
	C3 M100 D6 10.0 A, 560/680 VDC	Y	SMH1424515524	MOK 57/.. <sup>1)</sup>	REK41/.. <sup>1)</sup>		
	C3 M150 D6 15.0 A, 560/680 VDC	Z	SMHA1424515524	MOK 57/.. <sup>1)</sup>	REK41/.. <sup>1)</sup>		
GR10	C3 M100 D6 10.0 A, 560/680 VDC	X	SMH1424515524	MOK 55/.. <sup>1)</sup>	REK42/.. <sup>1)</sup>		
	C3 M150 D6 15.0 A, 560/680 VDC	Y	SMH1424515524	MOK 57/.. <sup>1)</sup>	REK41/.. <sup>1)</sup>		
	C3 M150 D6 15.0 A, 560/680 VDC	Z	SMHA1424515524	MOK 57/.. <sup>1)</sup>	REK41/.. <sup>1)</sup>		

Type	GL2 - GL5	GR2 -GR10
Power supply PSU P10D6	10kW 3*400/480V/AC	10kW 3*400/480V/AC

## Length code for cables

<sup>1)</sup> Length code 1 (Example MOK55/09 = length 25 m)

Length [m]	1,0	2,5	5,0	7,5	10,0	12,5	15,0	20,0	25,0	30,0	35,0	40,0	45,0	50,0
Order code <sup>1)</sup>	01	02	03	04	05	06	07	08	09	10	11	12	13	14

# Gantries Overview

Line-gantry	Axis	Module	max. stroke [mm]	max. load [kg]	hints
GL02	X	LBB080	5000	60	see page 8-9
	Z	ZEB050	1500	30	
GL03	X	LEB100	5500	110	
	Z	ZEB080	1500	50	
GL04	X	LBB120	8500	130	
	Z	ZEB080	1500	75	
GL05	X	LBB120	8500	250	
	Z	ZEB100	2000	150	

Space-gantry	Axis	Module	max. stroke [mm]	max. load [kg]	hints
GR02	X	LBB080	4900	120	see page 10-11
	Y	LBB080	2000	60	
	Z	ZEB050	1500	30	
GR03	X	LEB100	5500	210	
	Y	LEB100	2500	110	
	Z	ZEB080	1500	50	
GR06	X	LBB120	8500	310	
	Y	LBB120	3900	130	
	Z	ZEB080	1500	75	
GR08	X	LBB120	8500	400	
	Y	LBB120	2500	250	
	Z	ZEB100	2000	150	
GR10	X	LEB150	7400	500	
	Y	LEB150	3500	250	
	Z	ZEB100	2000	150	



Fig. shows GL04 standard gantry

# Order Code

Standard-Gantry		G						/			/								
<b>Type / Size</b>																			
<b>See table on page 11</b>																			
<b>Line gantry</b>		G	L																
LBB080 (X),	ZEB050 (Z)	G	L	0	2														
LEB100 (X),	ZEB080 (Z)	G	L	0	3														
LBB120 (X),	ZEB080 (Z)	G	L	0	4														
LBB120 (X),	ZEB100 (Z)	G	L	0	5														
<b>Space gantry</b>		G	R																
LBB080 (X),	LBB080 (Y),	ZEB050 (Z)	G	R	0	2													
LEB100 (X),	LEB100 (Y),	ZEB080 (Z)	G	R	0	3													
LBB120 (X),	LBB120 (Y),	ZEB080 (Z)	G	R	0	6													
LBB120 (X),	LBB120 (Y),	ZEB100 (Z)	G	R	0	8													
LEB150 (X),	LEB150 (Y),	ZEB100 (Z)	G	R	1	0													
<b>Steel strip cover</b>																			
All axes without steel strip cover																			N
X and - if exist Y-axis with steel strip cover(IP30)																			C
<b>Stroke X-axis</b>																			
Indicate Stroke (in mm)								n	n	n	n								
<b>Stroke Y-axis</b>																			
With GR: indicate stroke (in mm)									n	n	n	n							
With GL: indicate „0000“									0	0	0	0							
<b>Stroke Z-axis</b>																			
Indicate stroke (in mm)										n	n	n	n						
<b>Energy supply chain</b>																			
without energy chain																			N
inclusive energy chain																			E
<b>Drive package</b> (Motor, controller, cable)																			
Gearbox (without drive package)																			N
Gearbox (Inclusive drive package)																			A
<b>Motor / encoder system</b>																			
Without drive package																			N
Resolver																			R
Multiturn SinusCosinus																			M
(absolute value encoder)																			
<b>Compax3 fieldbus option</b>																			
Without drive package																			N
analog and step/direction input																			A
Profibus DP																			P
CANopen																			C
Ethernet POWERLINK																			D
EtherCAT®																			E
PROFINET																			F
<b>Free length of cable between switch cabinet and cable management</b>																			
Without drive package																			N
cable length 5 m																			1
cable length 10 m																			2
cable length 15 m																			3
cable length 20 m																			4
cable length 25 m																			5
cable length 30 m																			6
cable length 35 m																			7
cable length 40 m																			8
cable length 45 m																			9

More Information available under:

[www.parker-handlingsystems.com](http://www.parker-handlingsystems.com)

